

IGNITION COIL TESTER



OPERATION MANUAL

Version 2007.06

CONTENTS	Page
1. Introduction	3
2. Safety Precautions	4
3. Precautions to be taken during usage	6
4. Accessories	7
5. Indicators	8
6. Features	10
7. Operations	10
8. Connection Methods	16
9. Ignition Coil Connector Pin out Connections	22
10. Disclaimer	39
11. Limited Warranty	40
12. Limitations of Warranty	42

1. INTRODUCTION

Do you know that about 30% of all engine problems were arisen from ignition systems faults?

Diagnosing ignition system faults can be quite difficult if no proper tools to assist in the process of checking.

As we know, vehicle ignition system comprises of ignition coil (conventional type, COP, CNP, DECOP, etc), high tension cable, spark plugs, distributors, etc. Amongst all, ignition coil is the heart of the system that produces the vital high energy sparks that give rise to combustion.

To diagnose the condition of these high tension coils can be difficult if it is weak which has been aged over time or there is a leak internally.

With the introduction of this **IGNITION COIL TESTER**, checking the conditions of various types of ignition coils (normal, COP, DECOP, etc) has made much easier and safer when working with these high tension units.

2. SAFETY PRECAUTIONS:

To prevent accidents that could possibly result in serious injury and/or damage to vehicles and/or test equipment, carefully observe all safety rules and test procedures when working on vehicles.



When the engine is running, it produces carbon monoxide, a toxic and poisonous gas. Always operate the vehicle in a well ventilated area. Do not breathe exhaust gases – they are hazardous that can lead to death if inhaled in excessive amount.



Fuel and battery vapors are highly flammable. **DO NOT SMOKE NEAR THE VEHICLE DURING TESTING.**



Before starting the engine for testing or trouble shooting, always make sure the **parking brakes are firmly engaged**. Put the transmission in **Park** (automatic transmission) and **Neutral** (manual transmission).



Always block the drive wheels.
Never leave vehicle unattended while testing.



Engine parts become very hot when the engine has been run for awhile even though it was switched OFF. To prevent severe burns, avoid contact with hot engine parts.



Never lay tools on vehicle battery. You may short the terminals together causing harm to yourself, the tools or the battery.



When the engine is running, be cautious when working around the ignition coil, distributor cap, ignition wires and spark plugs. They are HIGH VOLTAGE components that can cause electrical Shock.



Always keep a fire extinguisher readily available and easily accessible in the workshop.

3. Precautions to be taken during usage:

- Do not operate the Ignition Coil Tester for more than 5 minutes on the coil being tested to avoid over heating and damage it.
- Spark gap distance of the Spark Tester needs to be adjusted according to the type of the coil. The higher the engine cylinder capacity, the bigger the gap distances are.
- Use only 12VDC power supply - which can be powered either by the car battery or external 12VDC power source when doing tests on the work bench.
- The described testing procedures in this manual are for references only. Always refer to the Car Service manuals for better information.
- Always turn the ignition speed adjustment knob to the lowest speed before connecting the signal cable to the spark tester.
- Always check the hook up connections again to ensure that it was correctly connected before applying power to the ignition coil tester.

4. Accessories:

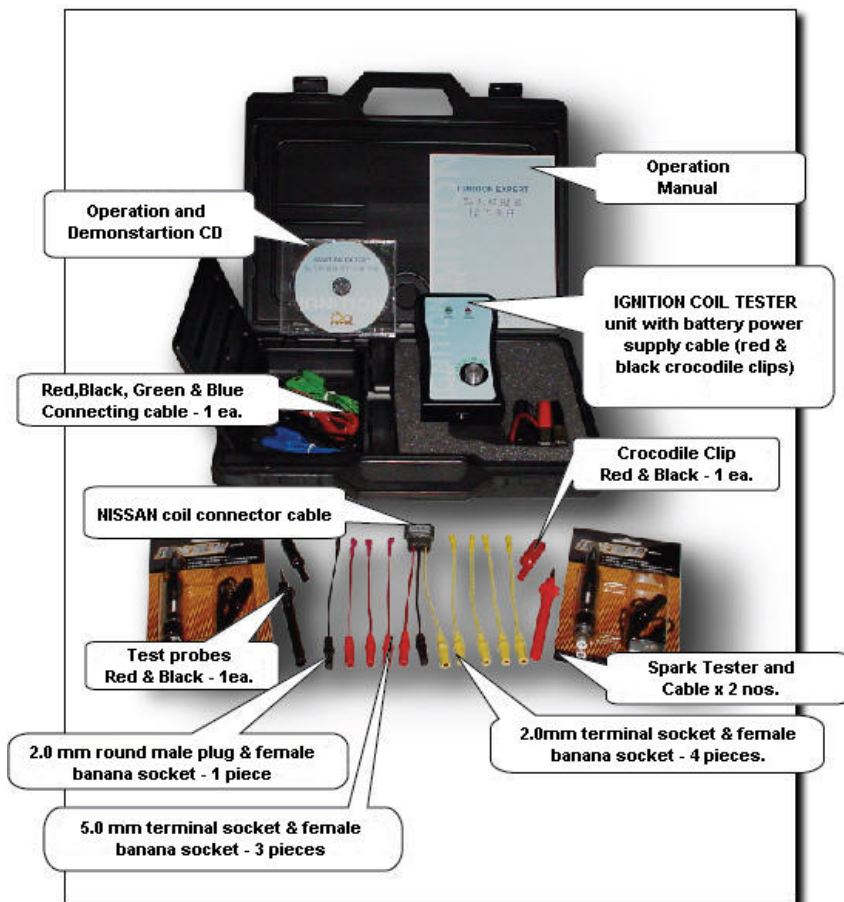

Figure 1

5. Indicators:

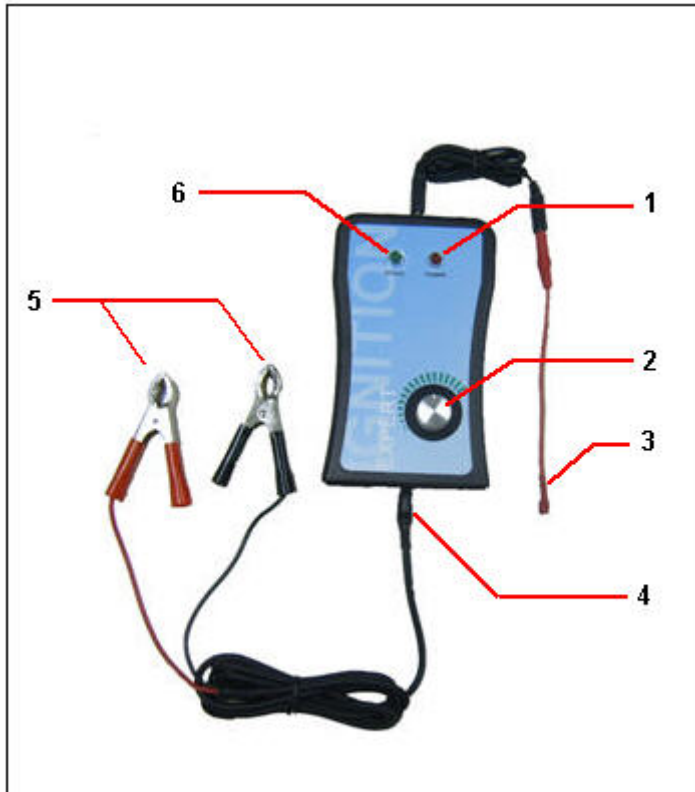

Figure 2
Ignition Coil Tester main unit

1. Power LED Indicator

This red LED lights up when 12VDC is supplied to the unit.

2. **Ignition speed adjustment knob**

To increase the ignition speed, turn the knob to clockwise direction. Likewise turn to counter clockwise will reduce the speed. Adjustable simulated speed ranges from 180 ~ 12,000 RPM.

3. **Ignition coil signal cable**

This cable is connected to the ignition coil's signal pin.

4. **Power input socket**

When the 12VDC power is plugged into this socket, the unit powers up and the red LED indicator will lights up.

5. **Battery post clips**

Connect these clips to the battery post if the power to the tester is to be supplied by the car battery.

6. **Ignition speed LED Indicator**

This green LED will pulse or flashes according to the simulated speed adjustment control setting.

6. Features:

1. This Ignition Coil Tester can automatically distinguish the type of the ignition coil that is being tested and will auto-switches its operation mode.
2. The simulation speed control can be adjusted from slow to fast as according to the test requirement. It ranges from 180 - 12000 RPM.
3. It has a built-in safety protection circuit design to protect against wrong hook up connection during testing.

7. Operation:

1. Switch the ignition key to “OFF” position.



Figure 3

2. Disconnect the connector to the ignition coil and check the pin out connections on the coil side. (Refer to section 9. - Ignition coil connector pin out connections)
3. Connect up the tester to the ignition coil as according the suggested methods outlined given according to the types of ignition coil (example: normal coil hook-up as below).

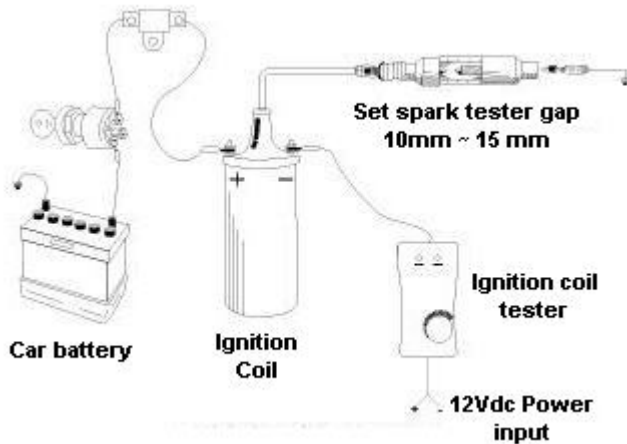

Figure 4

4. Use 12V car battery power if needed to test it on the vehicle. When the power is connected, the unit's red power LED indicator lights up.

5. Select a connection cable and connect it to the yellow banana socket located at the top of the unit to the negative (-) or signal input of the ignition coil (depending on the types of the coil).
6. Turn the ignition key to “ON” position. **DO NOT** crank or start the engine. (See figure 5).

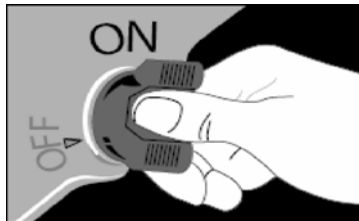

Figure 5

7. Turn the coil tester ignition speed knob clockwise to switch on. Adjust this switch fast or slow according to requirement.



Figure 6

8. Adjust to the lowest speed; observe spark color (should be bluish purple color) when connected to the spark tester (Figure 7).

9.



Figure 7
Spark Tester

10. Observe the spark created. Normal spark should have a straight and continuous arc line (Figure 8).



Figure 8
Normal arc shape

11. If spark has an abnormal shape or curved arc, this is an indication that an internal leakage is present or the coil has aged (Figure 9 & 10).



Figure 9



Figure 10

Abnormal arc shapes

12. Turn the coil tester to higher ignition speed until the coil is slightly heated.
13. Then turn it down to a lower ignition speed; observe whether the arc is continuous or intermittent.
14. If 'clicking' electrical noises are heard but there is no arc present, it means that the ignition coil has an internal high voltage leakage.
15. To check the leaks, use the **Ignition Leak Checker** (Figure 11) to check whether there is any high voltage leakage or not.



Figure 11
Ignition Leak Checker

16. If there is a high voltage leakage, a visible spark is noticed and the Ignition Leak Checker indicator LED will blink simultaneously.



Figure 12



Figure 13

17. After the checking procedures has finished and there is a need to disconnect the checker, first turn the ignition key to 'OFF' position.



Figure 14

18. Turn down the ignition speed adjustment (Figure 15).

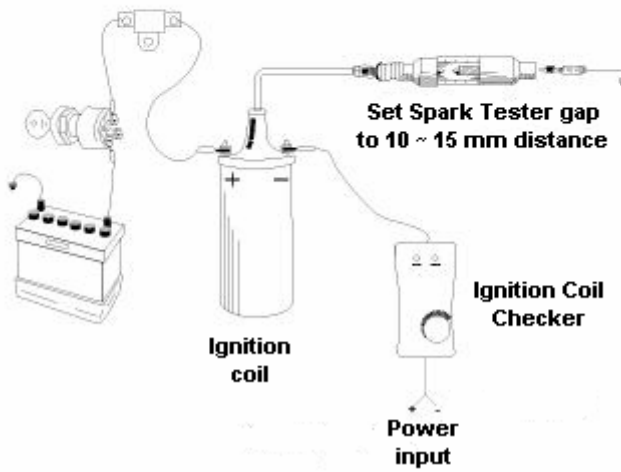

Figure 15

19. Then unplug the 12VDC power from the tester and then remove the connections and put them back safely into the carry case.

8. Connection methods:

1. **Ford Laser – Year 1988** or other similar ignition system.



2. **BMW 520 (E34) – Year 1995** or other similar ignition system.



Coil on plug (COP) or Coil near plug (CNP)

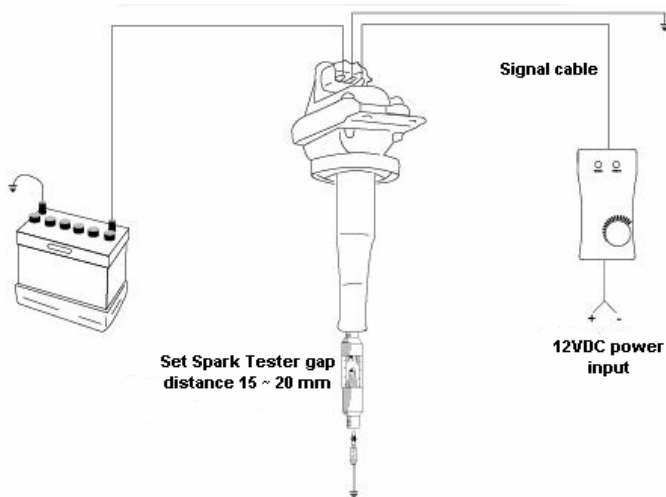

3. **M. BENZ E320 (W210 & M104)**
Year 1995 or other similar ignition
system.



Double ended Coil on plug (DECOP)

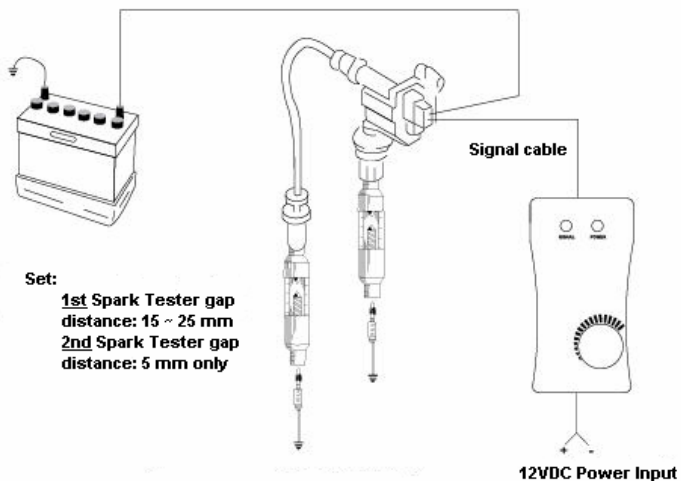

5. **HONDA CR-V – Year 2003** or other similar ignition system.



Coil on Plug (COP) or Coil near plug (CNP)

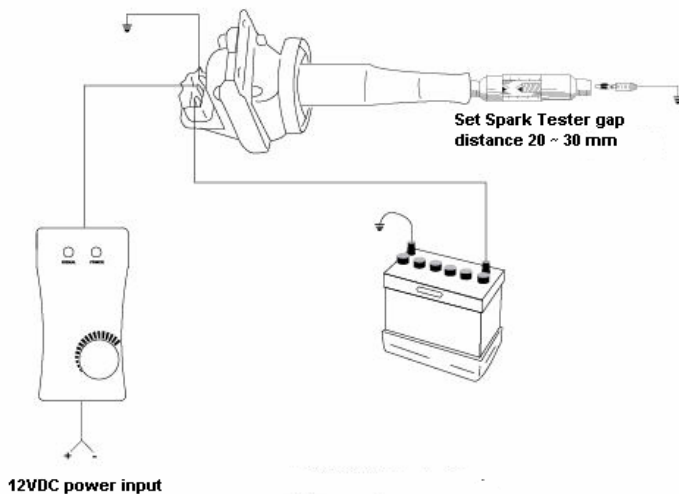

6. **FORMOSA MAGNUS – Year 2000**
or other similar ignition system.



Double ended Coil on plug (DECOP)

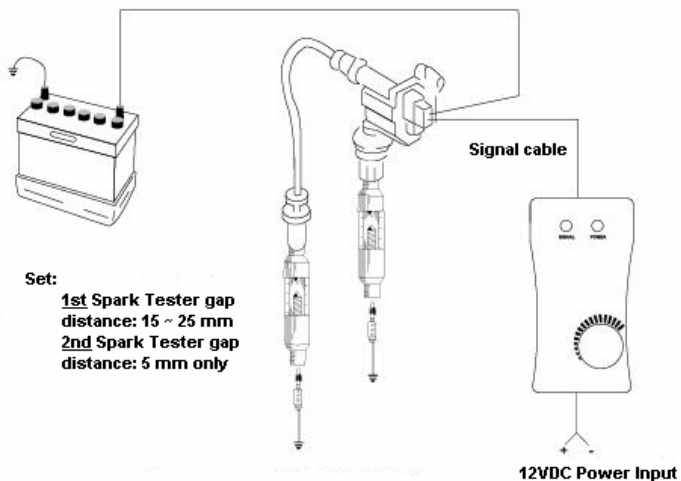

9. IGNITION COIL CONNECTOR PIN OUT CONNECTIONS:

1. **BMW**

Models: E39 (1996 ~ 1998)
M52 (1996 ~ 1998)
520 (1991 ~ 1995)
525 (1991 ~ 1995)

Capacity: 2.0L
2.5L
2.8L

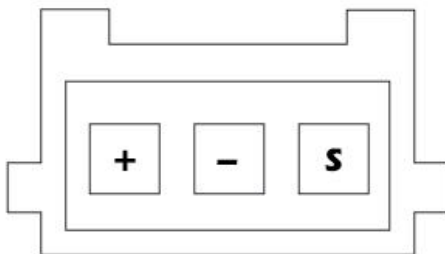

S: Ignition signal

+: Positive voltage

- : Negative voltage

2. CHRYSLER

Model: Concord

Capacity: 3.3L (1993 ~ 1997)
 3.5L (1996 ~ 1997)

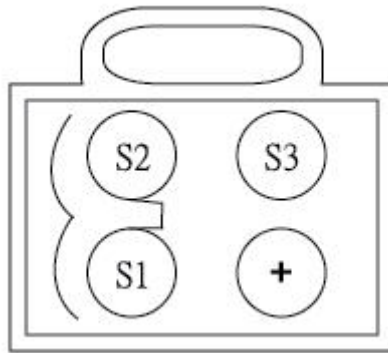

S1: Ignition Signal – CYL 1 & CYL 4

S2: Ignition Signal – CYL 2 & CYL 5

S3: Ignition Signal – CYL 3 & CYL 6

+: Positive voltage

3. CHRYSLER

Model: Neon (1995 ~ 1996)

Capacity: 2.0L

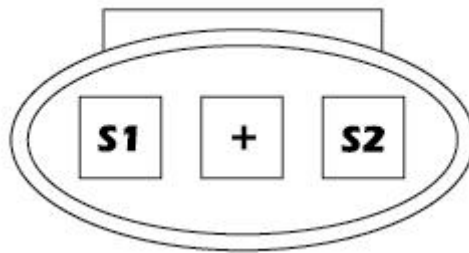

S1: Ignition Signal – CYL 1 & CYL 3

S2: Ignition Signal – CYL 2 & CYL 4

+: Positive voltage

4. CHRYSLER

Model: Stratus (1995 ~ 2000)

Capacity: 2.0L
2.4L
2.5L

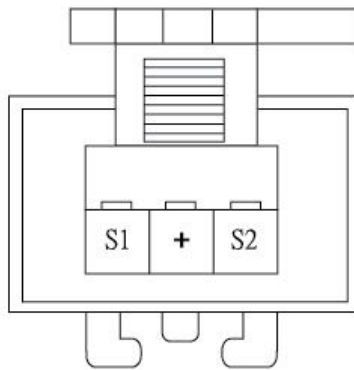

S1: Ignition Signal – CYL 1 & CYL 3

S2: Ignition Signal – CYL 2 & CYL 4

+: Positive voltage

5. DAEWOO

Model: Magnus (Year 2000)

Capacity: 2.0L

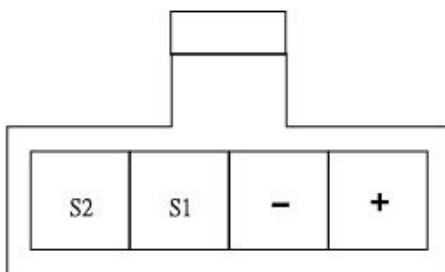

S1: Ignition Signal – CYL 1 & CYL 4

S2: Ignition Signal – CYL 2 & CYL 3

+: Positive voltage

-: Negative voltage

6. FORD

Model: Escape (Year 2000)

Capacity: 2.0L
3.0L

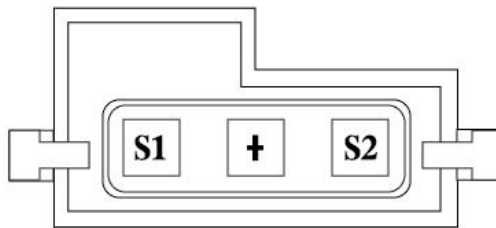

S1: Ignition Signal – CYL 1 & CYL 4

S2: Ignition Signal – CYL 2 & CYL 3

+: Positive voltage

7. FORD

Model: Metrostar (2001 ~ 2002)

Capacity: 2.0L

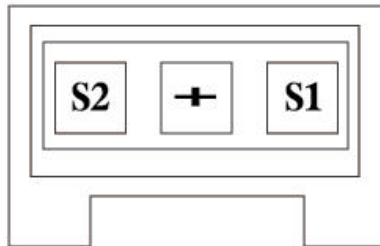

S1: Ignition Signal – CYL 1 & CYL 4

S2: Ignition Signal – CYL 2 & CYL 3

+: Positive voltage

9. FORD

Model: Mondeo (1997 ~ 1999)

Capacity: 2.0L

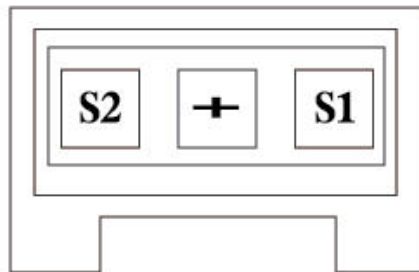

S1: Ignition Signal – CYL 1 & CYL 4

S2: Ignition Signal – CYL 2 & CYL 3

+: Positive voltage

10. MAZDA

Model: MPV (1999 ~ 2002)

Capacity: 2.5L

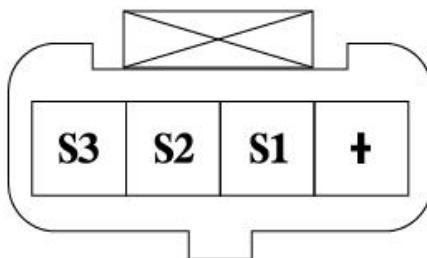

S1: Ignition Signal – CYL 1 & CYL 5

S2: Ignition Signal – CYL 2 & CYL 6

S3: Ignition Signal – CYL 3 & CYL 4

+: Positive voltage

-: Negative voltage

11. MAZDA

Model: Premacy (2001 ~ 2003)

Capacity: 1.8L
2.0L

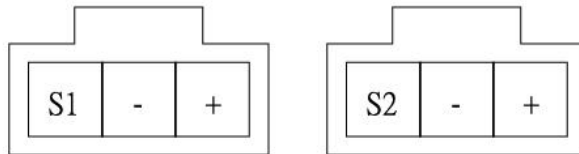

S1: Ignition Signal – CYL 1 & CYL 4

S2: Ignition Signal – CYL 2 & CYL 3

+: Positive voltage

-: Negative voltage

12. MERCEDES BENZ

Models: C180 (2000 ~ 2002)
C200 (2000 ~ 2002)
C240 (2000 ~ 2002)
C320 (2000 ~ 2002)

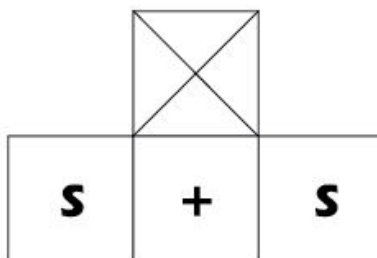

S: Ignition signal

+: Positive voltage

13. MITSUBISHI

Model: Savrin (2001 ~ 2002)

Capacity: 2.0L

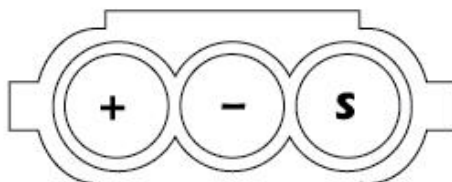

S: Ignition Signal

+: Positive voltage

- : Negative voltage

14. NISSAN

Model: Cefiro (1995 ~ 1997)
Sentra (2000 ~ 2001)

Capacity: 1.8L
2.0L
3.0L

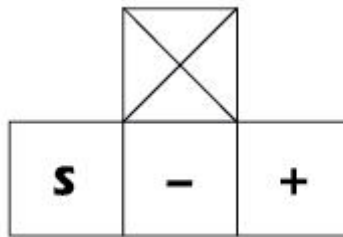

S: Ignition Signal

+: Positive voltage

- : Negative voltage

15. OPEL

Model: Corsa (1994 ~ 2000)

Capacity: 1.4L

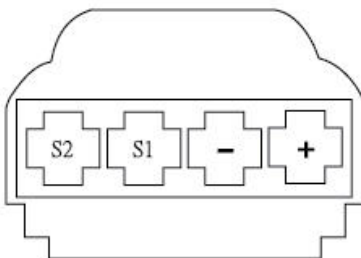

S1: Ignition Signal – CYL 1 & CYL 4

S2: Ignition Signal – CYL 2 & CYL 3

+: Positive voltage

-: Negative voltage

16. TOYOTA

Model: Camry (2003)

Capacity: 2.0L
3.0L

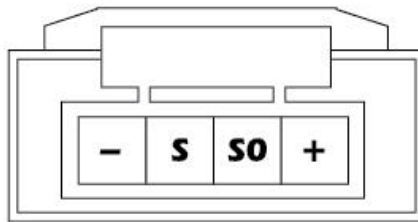

S: Ignition Signal

S0: Ignition Signal Return

+: Positive voltage

- : Negative voltage

17. TOYOTA

Model: Camry (1997 ~ 1999)
Hiace (1996 ~ 2000)

Capacity: 2.2L
2.7L

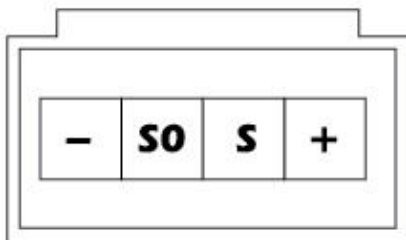

S: Ignition Signal

S0: Ignition Signal Return

+: Positive voltage

- : Negative voltage

18. TOYOTA

Model: Premio (1997 ~ 2001)

Capacity: 2.0L

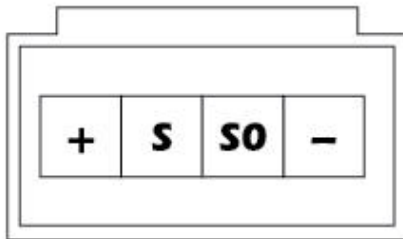

S: Ignition Signal

S0: Ignition Signal Return

+: Positive voltage

- : Negative voltage

10. **Disclaimer**

All information, illustrations, and specifications contained in this user manual were based on the latest information available at the time of printing. The right is reserved to make any changes at any time without obligations to notify any person or organization of such revisions or changes.

Furthermore, the manufacturer or its sales agents are not liable for errors contained herein or for incidental or consequential damages (including lost profits) in connection with the furnishing, performance or use of this material.

This user manual tells how to use the IGNITION COIL TESTER kit to perform the required procedures on checking of the ignition coils.

Safe and effective use of this TESTER is very much dependant on the user following the normal practices and procedures outline in this manual.

11. Limited Warranty

This limited warranty cover defects in materials and workmanship for a period of six (6) months which begins from the date the product is purchased by the end user and is subjected to the following terms and conditions:

- Within the warranty period, the manufacturer will repair or replace, at their options, any defective parts and return to the owner in good working condition.
- Any repaired or replaced parts will be warranted for the balance of the original warranty or three months (3) months from the date of repair, whichever is longer.
- This warranty only extends to the first owner and not assignable or transferable to any subsequent owner.
- Cost of delivery charges incurred for the repair of the product to and from the manufacturer will be borne by the owner.
- This limited warranty covers only those defects that arises as a result of normal use and does not cover those that arises as a result of:
 - Unauthorized modifications and repair.
 - Improper operation or misuse.
 - Accident or neglect such as dropping the unit onto hard surfaces.

- Contact with water, rain or extreme humidity.
- Contact with extreme heat.
- Cables that have broken, bent contact pins or subject to extreme stress or wear.
- Physical damage to the product surface including scratches, cracks or other damage to the display screen or other externally exposed parts.

12. Limitations of Warranty

Other than the foregoing limited warranty, the manufacturer does not make any other warranty or condition of any kind, whether express or implied.

Any implied warranty of merchantability, or fitness for use shall be limited to the duration of the foregoing limited warranty.

Otherwise, the foregoing limited warranty is the owner's sole and exclusive remedy and is in lieu of all other warranties whether express or implied.

The manufacturer or any of its exclusive sales agents shall not be liable for any consequential or incidental damages or losses arising of the loss of uses of this product.

All warranty information, product features and specifications are subjected to change without prior notice.